

FE/PIPE v6.5

- ASME Material Database Update
- PRG Branch Connection Super-Element Library
- i-factor and k-factor Calculation and Comparison Spreadsheet
- Updated 2D and 3D Plasticity
- DirectX 3D View and Animation Updates – enhanced colorization controls, non-deformed shape shading, and options for including multiple models in the same viewing window.
- Nozshell Moment Boundary Conditions (to simulate Code bolt-up conditions on flat heads and other Nozshell components)
- New Graphical User Interface for PCL-Gold pipe stress module – see PCL-Gold update features below. ***(PCL-Gold is available to those FE/Pipe clients with active support agreements). PCL-Gold has been extensively overhauled with a unique new suite of features for advanced piping analysis.***

FETee B16.9 and Contoured Tee Modeler. Evaluates i-factors, k-factors and loads for finite element models of contoured fittings. ***(This module is available as part of the FE series of lease products and provided to FE/Pipe clients with active support agreements).***

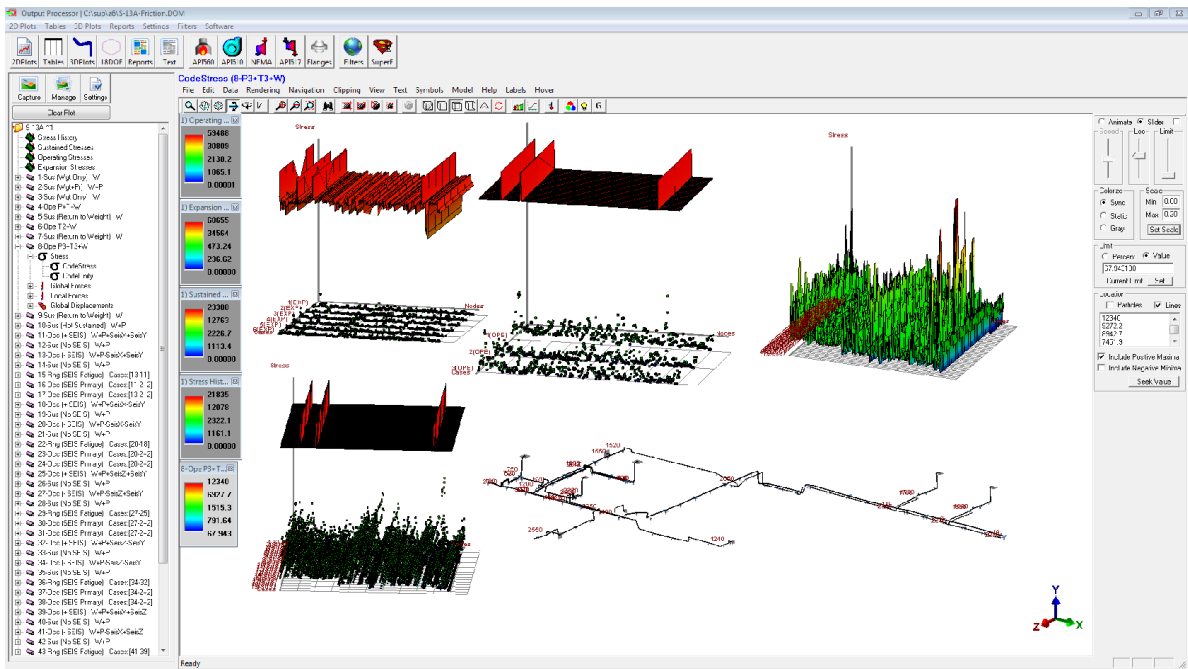

- Path Dependent Friction
 - *Very stable, highly convergence - more accurate than “Final State Guess” algorithms, or “Adjustable Stiffness” algorithms that cannot follow the path dependence of friction.*
- Pressure cycling calculation included with evaluation of external piping loads.
- Automatic multiple load case cycle life consumption calculation on a node-by-node and load-case-by-load case basis. (Multiple load case fatigue cycles should be computed on a node by node basis for all but simple systems.)
- 10 i-factors for branch connections from FEA database and 8 k-factors.
- i-factors for heads and branch connections included welding tees
 - *Light, medium and heavy wall constructions based on PRG measurement. (These contoured thicknesses are not covered effectively by B16.9 and results may vary significantly.)*
- k-factors for heads – including spheres, dished, elliptical, conical and flat heads and branch connections in cylinders *from FEA or PRG correlation-based methods. (Users can also compare these methods to WRC 107, WRC 297 and advanced B31 results.)*
- 18dof refractory lined pipe, or glass lined pipe. Can also be used to accurately evaluate clad lined piping systems. The stiffness and stress effect of the cladding can be evaluated on the loads and stresses in the piping system. Output includes standard B31 code evaluation along with the local stresses in the cladding.
- Rotating equipment reports for all load cases automatically
- High frequency and mode estimates for straight cylinders.
- Multiple sustained stress case i-factor options
- Structural elements as part of the piping input
- PROGRAM Control button for SIF and STIFFNESS models. Users can toggle between FEA, Advanced B31, PRG, WRC107/297 methods for i-factors and k-factors used in the piping analysis. This gives the user an accurate estimate of how much loads on rotating equipment and how much stresses in the system can vary based on flexibilities of the branch connections.

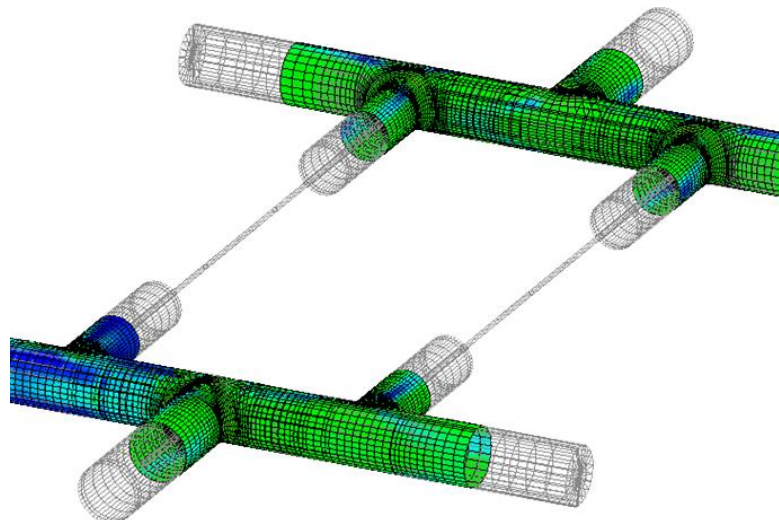

NOZZLEPRO v8.5

- Pressure cycling calculation
Up to 200 different pressure+load combinations for fatigue analysis
- Automatic multiple load case fraction cycle consumption
- k-factor addition to output reports
- WRC 497 length recommendations for boundary condition removal
- Branch and Run Load stress combinations for up to 200 different load combinations for fatigue analysis.
- Cycle consumption is per VIII-2 Annex 5.E..2
- Probabilistic Seismic/Wind/Impact Fatigue Contribution
- i-factor and k-factor spreadsheet for FEA comparison
- **Effective 15 February 2012, NozzlePRO will automatically include MatPRO, Fitness for Service and NH Reporting (High Temperature). NozzlePRO clients who have active support as of this date will be eligible to access all of these modules.**

"Paulin Research Group" - i-factors, k-factors and Stiffnesses

Run Pipe Geometry

Outside Diameter (Do)

Wall Thickness (T)

Branch Geometry

Outside Diameter (do)

Wall Thickness (t)

Pad Thickness (tp)

Crotch Radius (rx)

Local Nozzle Thk (tn)

Extra Data

r/p

Modulus of Elasticity

Compute/Update i, k and K

Calculate r/p

Calculated Properties

Moment of Inertia (run)	279.34
Moment of Inertia (branch)	7.2326
Mean Diameter (run)	12.375
Mean Diameter (branch)	4.2630
Flexibility Characteristic, h	0.06263
One end flanged, c=h ^{1/6}	0.630
Two ends flanged, c=h ^{1/3}	0.397
Bend ki, ko = 1.3/h	20.756

PRG i-factors and k-factors for Branch Connections

		iib	iob	itb	iir	ior	itr	kib	kob	ktb	kir	kor	ktr
Sketch 2.1	WLT	1.0000	1.2240	1.0000	1.0000	1.0000	1.0000	1.0000	2.5118	1.0000	1.0000	1.0000	1.0000
Sketch 2.2	RFT	1.7895	2.3444	1.0000	1.5000	1.0000	1.0000	1.8045	5.3568	1.0000	1.0000	1.0000	1.0000
Sketch 2.3	UFT	2.5988	4.6143	1.0000	2.5381	1.0000	1.2440	4.9531	13.611	1.0000	1.0000	1.0000	1.0000
Sketch 2.4	EXT	1.7170	2.6373	1.0000	1.0000	1.0000	1.0000	1.0000	2.5118	1.0000	1.0000	1.0000	1.0000
Sketch 2.5	SWP	1.0000	1.6903	1.0000	1.0000	1.0000	1.0000	1.0499	5.1082	1.0000	1.0000	1.0000	1.0000
Sketch 2.6	OLET	1.5680	3.0490	1.0000	1.5000	1.0000	1.0659	1.0000	4.3903	1.0000	1.0000	1.0000	1.0000
Sketch 2.3	Thk Noz	2.5988	4.6143	1.0000	2.5381	1.0000	1.5000	4.9531	13.611	1.0000	1.0000	1.0000	1.0000

B31 i-factors and k-factors for Branch Connections

		iib	iob	itb	iir	ior	itr	kib	kob	ktb	kir	kor	ktr
Sketch 2.1	WLT	1.4585	1.7340		2.3077	2.7436							
Sketch 2.2	RFT	1.5647	1.8756		2.4757	2.9677							
Sketch 2.3	UFT	2.9229	3.6865		4.6248	5.8331							
Sketch 2.4	EXT	2.8578	3.5998		4.5219	5.6958							
Sketch 2.5	SWP	1.4585	1.7340		1.4585	1.7340							
Sketch 2.6	OLET	1.6632	1.6632		2.6316	2.6316							

NC/NB i-factors and k-factors for Unreinforced Fabricated Tees

		iib	iob	itb	iir	ior	itr	kib	kob	ktb	kir	kor	ktr
Sketch 2.1	WLT	2.1712	2.1712	2.1712	2.1712	2.1712	2.1712						
Sketch 2.3	UFT	3.4163	3.4163	3.4163	2.1000	2.1000	2.1000	3.2116	9.3633				

DNV i-factors for Unreinforced Fabricated Tees

		iib	iob	itb	iir	ior	itr	kib	kob	ktb	kir	kor	ktr
Sketch 2.3	UFT	1.4921	3.1357										

Wais i-factors and k-factors for Intersections

		iib	iob	itb	iir	ior	itr	kib	kob	ktb	kir	kor	ktr
Sketch 2.2	RFT	1.6192	2.9870	1.0000	1.5813	1.0000	1.3286	2.9439	7.7984	1.0000	1.0000	1.0000	1.0000
Sketch 2.3	UFT	2.4786	5.2711	1.0000	1.4959	1.0000	1.3044	4.9447	15.663	1.0000	1.0000	1.0000	1.0000

Widera i-factors and k-factors for Unreinforced Fabricated Tees

		iib	iob	itb	iir	ior	itr	kib	kob	ktb	kir	kor	ktr

AXIPRO v3.5

Increased reliability for large diameter flanges.

MATPRO v3.5

Updated ASME and B31 Material Databases

FE Series of Products *(FE Products are available as annual leases)*

FESIF v2.5

- Improved meshing algorithm – Improved mesh quality
- Includes flexibility factor in output reports

FE107 v2.5

- Automatic multiple load case fraction cycle consumption
- Addition of Load History

FE661 v1.5

- Option to enter API 661 Load Multiplier. In many cases, FEA must pass 2 or 3 times the API loads.

API 661 Evaluation
API Multiplier

FE661 will become 661PRO with the next release. As of 15 February 2012 it will become a permanent part of FE/Pipe. FE/Pipe clients who have active support as of this date will receive permanent access to this module.

FEbend v1.5

- Option to free any restraint axially. Previously high thermal loads could cause a problem if both legs of the bend were fixed as there was no freedom to expand. This caused unrealistic high stresses at the boundary conditions:

Free Support Axially Free Leg #1 Axially Free Leg #2 Axially

INTRODUCING our newest FE Series product...

FETee v1.1

- Probabilistic Seismic/Wind/Impact Fatigue Contribution
- i-factor and k-factor spreadsheet for FEA comparison
- Automatic multiple load case fraction cycle consumption
- ASME B16.9 Database for welding tees
- Automatic crotch profile thickness assumptions based on run and branch thicknesses if not available.

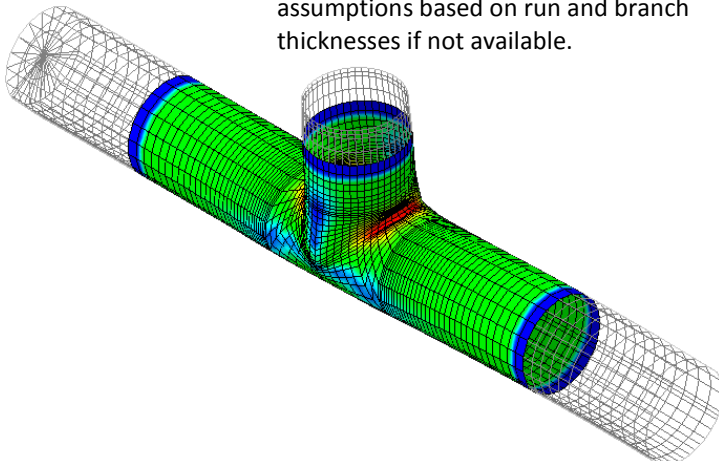

B16.9 Tee

Tee Type
 Straight Tee (Size-on-Size) Reducing Tee

1/2 x 1/2 x 1/4
3/4 x 3/4 x 1/2
3/4 x 3/4 x 3/8
1 x 1 x 3/4
1 x 1 x 1/2
1-1/4 x 1-1/4 x 1
1-1/4 x 1-1/4 x 3/4
1-1/4 x 1-1/4 x 1/2
1-1/2 x 1-1/2 x 1-3/4
1-1/2 x 1-1/2 x 1
1-1/2 x 1-1/2 x 3/4
1-1/2 x 1-1/2 x 1/2
2 x 2 x 1-1/2
2 x 2 x 1-1/4
2 x 2 x 1
2 x 2 x 3/4
2-1/2 x 2-1/2 x 2
2-1/2 x 2-1/2 x 1-1/2
2-1/2 x 2-1/2 x 1-1/4
2-1/2 x 2-1/2 x 1
3 x 3 x 2-1/2
3 x 3 x 2
3 x 3 x 1-1/2

Nominal Diameter(s)
Run Nom. Diam = 1
Branch Nom. Diameter = 0.5

B16.9 Run Distance (C)
1.5

B16.9 Centerline to Branch Weld Distance (M)
1.5